

**VIRGINIA  
STANDARDS OF LEARNING ASSESSMENTS**

**Spring 2001 Released Test**

---

**GRADE 8  
MATH**

# Property of the Virginia Department of Education

© 2001 by the Commonwealth of Virginia Department of Education, James Monroe Building, 101 N. 14th Street, Richmond, Virginia, 23219. All rights reserved. Except as permitted by law, this material may not be reproduced or used in any form or by any means, electronic or mechanical, including photocopying or recording, or by any information storage or retrieval system, without written permission from the copyright owner. Commonwealth of Virginia public school educators may photocopy or print any portion of these Released Tests for educational purposes without requesting permission. All others should direct their requests to the Commonwealth of Virginia Department of Education at (804) 225-2102, Division of Assessment and Reporting.

## Mathematics

### DIRECTIONS

Read and solve each question. Then mark the space in the answer booklet for the best answer.

#### SAMPLE

**Vicki had \$228 in her checking account. She used \$37 to buy a birthday gift for her grandmother. After that, how much did she have left in her checking account?**

- A \$211
- B \$191
- C \$181
- D \$164

**1 If  $0.3 < x < 35\%$ , which of the following could be the value of  $x$ ?**

- A  $\frac{1}{4}$
- B  $\frac{1}{3}$
- C  $\frac{1}{2}$
- D 1

**2 What is the value of  $3 + 7(2^3 - 6)^2$ ?**

- F 23
- G 31
- H 84
- J 2,503

**3 A scale distance of 3.5 centimeters on a certain map represents an actual distance of 175 kilometers. What actual distance does 5.7 centimeters on the same map represent?**

- A 0.285 km
- B 2.85 km
- C 28.5 km
- D 285 km

**4 Which of the following is *not* a prime number?**

- F 2
- G 5
- H 17
- J 121

5

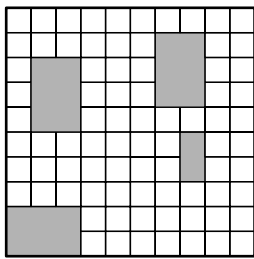

The shaded part of the square can be expressed by —

- A 0.02
- B 20%
- C  $\frac{1}{4}$
- D  $\frac{2}{5}$
- 6 Mia has 90 roses and 135 carnations to put into vases. She wants to put the same number of roses and the same number of carnations into each vase. What is the *greatest* number of vases that she will need in order to do this?
- F 5
- G 9
- H 15
- J 45

- 7 Which is closest to the location of point A on the number line?

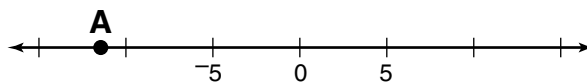

- A -11
- B -7
- C 7
- D 11
- 8 Which is an example of the associative property of multiplication?
- F  $7 \cdot 0 \cdot 9 = 0$
- G  $4 \cdot (7 \cdot -3) = 4 \cdot (-3 \cdot 7)$
- H  $\left(6 \cdot \frac{1}{6}\right) \cdot 3 = 3$
- J  $5 \cdot (3 \cdot -8) = (5 \cdot 3) \cdot -8$
- 9 Johanna rented a car. Rental costs were \$29.00 per day plus \$0.49 for each mile driven. If she kept the car for 1 day and drove 50 miles, how much did she owe?
- A \$29.49
- B \$31.45
- C \$53.50
- D \$78.00

- 10 Randy makes \$200 per week. His employer deducts 4% of his earnings for Randy's medical insurance. How much of his weekly salary does Randy pay for medical insurance?
- F \$80  
G \$8  
H \$0.80  
J \$0.08
- 11 Between which two consecutive whole numbers does  $\sqrt{42}$  lie?
- A 5 and 6  
B 6 and 7  
C 7 and 8  
D 8 and 9
- 12 What is the value of  $x^2(7 - x) + 2$  when  $x = 5$ ?
- F 52  
G 100  
H 152  
J 172
- 13 Mrs. Adams walks between  $\frac{4}{10}$  and  $\frac{6}{10}$  mile every day. Which is the *best* estimate of the number of miles she will walk in 30 days?
- A 12  
B 15  
C 18  
D 20
- 14 Chris used a copy machine to enlarge a drawing to 150% of its original size. If the width of the original drawing was 37 centimeters, what is the width of the copy of the drawing?
- F 37.0 cm  
G 55.5 cm  
H 92.5 cm  
J 150.0 cm
- 15 Pure water boils at 212° F. If a certain chemical is added to the water, the boiling point changes by -28° F. At what temperature does the new liquid boil?
- A 240° F  
B 184° F  
C -184° F  
D -240° F

16 If Gina measured the length of all 4 sides of the top of her desk and added them together, what would she have?

- F The diameter
- G The volume
- H The perimeter
- J The area

17 The angles in  $\triangle ABC$  measure  $27^\circ$ ,  $73^\circ$ , and  $80^\circ$ . What kind of triangle is  $\triangle ABC$ ?

- A Equiangular
- B Acute
- C Obtuse
- D Right

18 What is the volume of the square-based pyramid shown below?

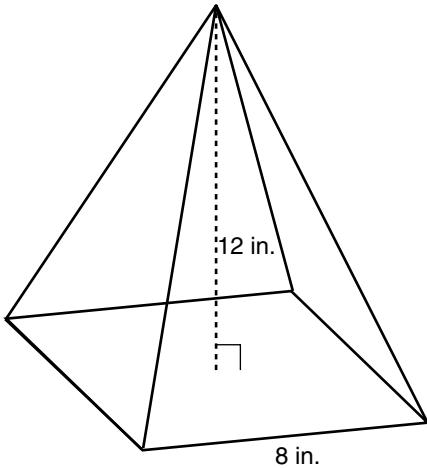

- F 96 cu in.
- G 256 cu in.
- H 384 cu in.
- J 768 cu in.

19 Each cube in this stack has a volume of 1 cubic unit, and each face of those cubes has an area of 1 square unit.

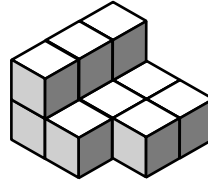

Which could be the surface area of this stack of cubes?

- A 18 sq units
- B 24 sq units
- C 29 sq units
- D 36 sq units

20

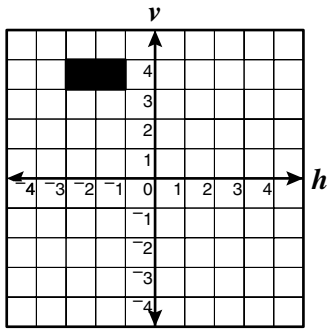

The dark rectangle is reflected over line  $v$ . Which shows this reflection?

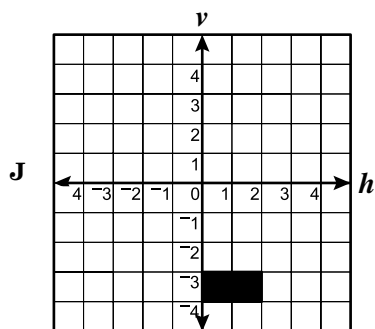
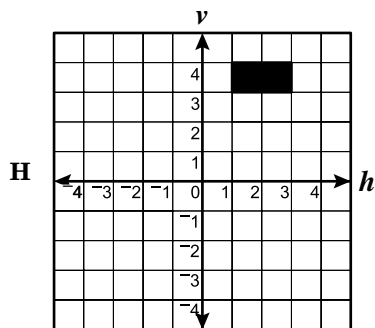
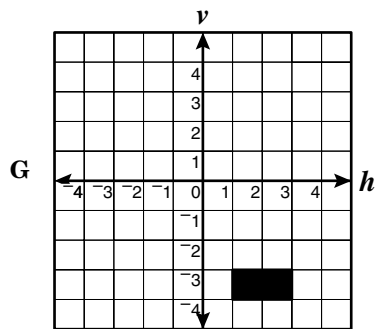
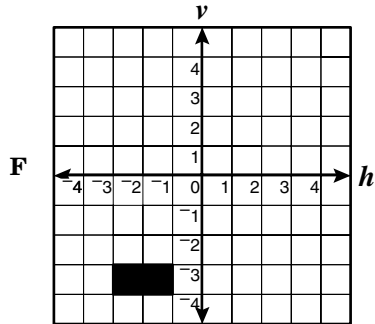

21

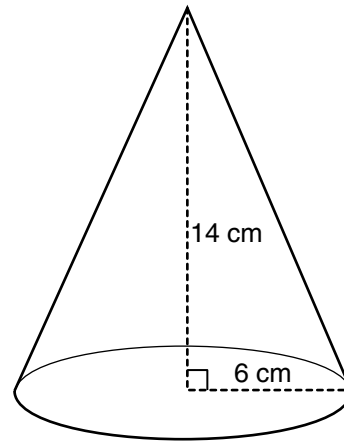

Which is *closest* to the volume of the cone shown above?

- A  $87.9 \text{ cm}^3$
- B  $395.6 \text{ cm}^3$
- C  $527.5 \text{ cm}^3$
- D  $1582.6 \text{ cm}^3$

22 Which is the *closest* to the circumference of a circle with a radius of 2.4 meters?

- F 7.5 m
- G 15.1 m
- H 18.1 m
- J 72.3 m

23 In this scale drawing, each square unit represents 1 square centimeter.

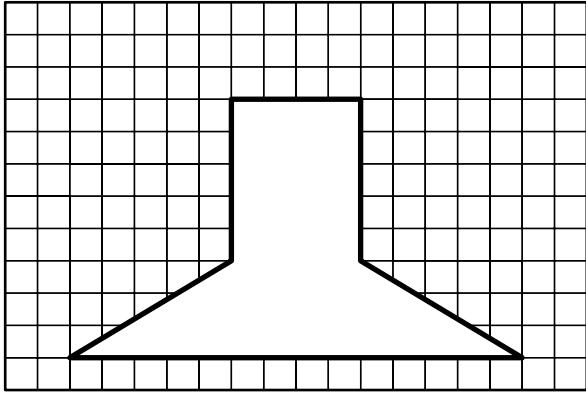

What is the area of the figure represented by the drawing?

- A  $15 \text{ cm}^2$
- B  $20 \text{ cm}^2$
- C  $32 \text{ cm}^2$
- D  $47 \text{ cm}^2$

24

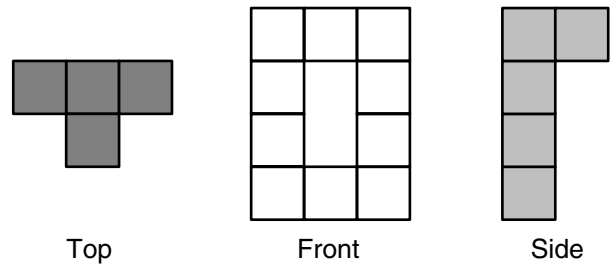

This shows 3 different views of a three-dimensional figure constructed from cubes. Which could be this figure?

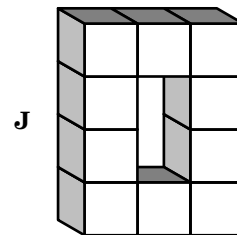
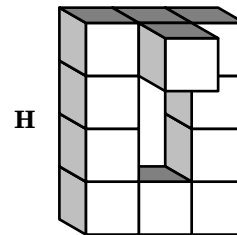
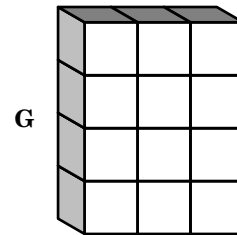
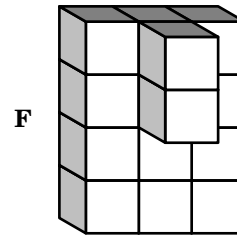



- 25 In  $\triangle ABC$ ,  $\overline{AB}$  measures 6 centimeters and  $\overline{BC}$  measures 8 centimeters.

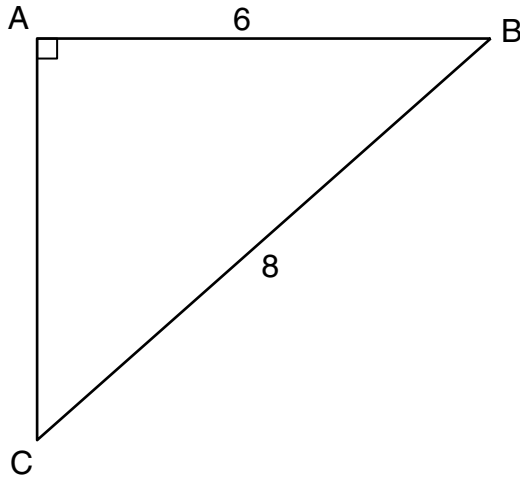

What is the length of  $\overline{AC}$ ?

26

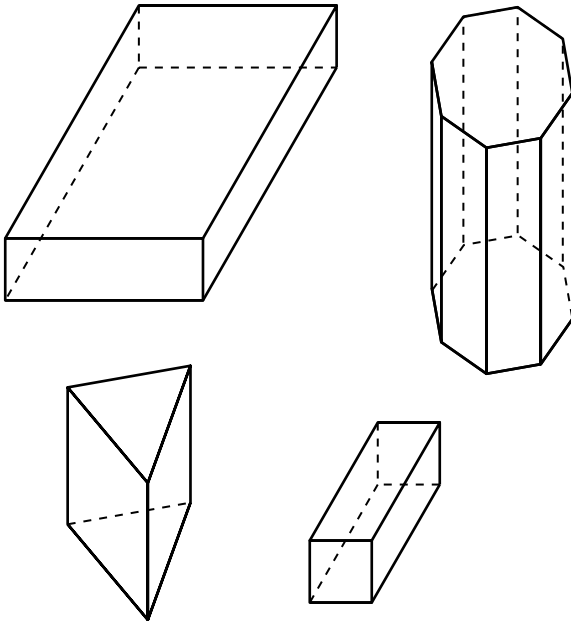

These figures are all —

- F pyramids
- G prisms
- H cylinders
- J cones

27

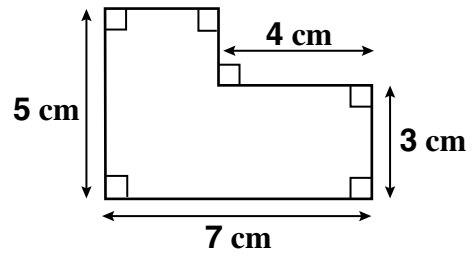

What is the area of this figure?

- A  $19 \text{ cm}^2$
- B  $24 \text{ cm}^2$
- C  $27 \text{ cm}^2$
- D  $35 \text{ cm}^2$

- 28 This shows three different views of a three-dimensional figure constructed from cubes.

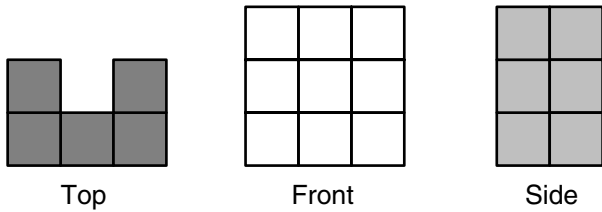

Which of the following could be the figure?

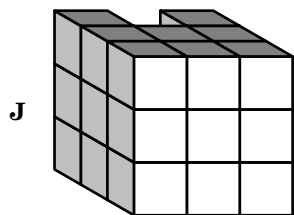
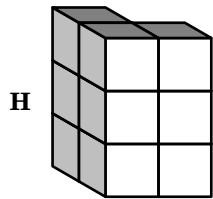
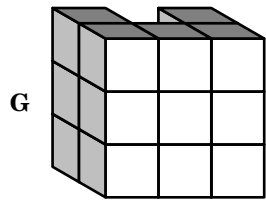
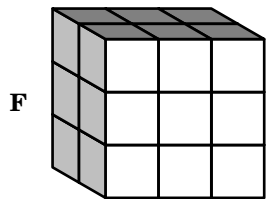

- 29 If  $\angle QRS$  and  $\angle XYZ$  are complementary, which *must* be true?

- A One of the angles can measure between  $90^\circ$  and  $180^\circ$ .
- B The sum of the measures of the angles is  $90^\circ$ .
- C The sum of the measures of the angles is  $180^\circ$ .
- D Both angles must measure more than  $90^\circ$ .

30

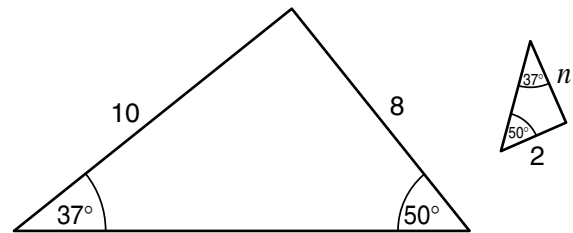

What is the length of side  $n$  on the second triangle?

- F 2
- G 2.5
- H 4
- J 5

- 31 Ada and Jim received awards for placing either first, second, or third in their respective divisions at each of the 12 track meets attended by the team. The table indicates the results.

Meet #	1	2	3	4	5	6	7	8	9	10	11	12
Ada	1st	1st	2nd	3rd	1st	1st	2nd	2nd	1st	1st	3rd	1st
Jim	2nd	2nd	1st	1st	3rd	2nd	3rd	1st	2nd	1st	1st	1st

Which matrix *best* organizes the information in the table?

A

	Ada	Jim
1st	6	7
2nd	4	3
3rd	2	2

B

	Ada	Jim
1st	7	6
2nd	4	3
3rd	2	2

C

	Ada	Jim
1st	7	6
2nd	3	4
3rd	2	2

D

	Ada	Jim
1st	6	6
2nd	5	3
3rd	2	2

- 32 The table shows the Math and English scores of Art and 4 of his friends.

Student	Math	English
Art	84	78
Bonnie	67	76
Cathy	92	85
Don	75	75
Ellie	78	88

Which scattergram correctly shows the relationship between Math and English scores for the group of friends?

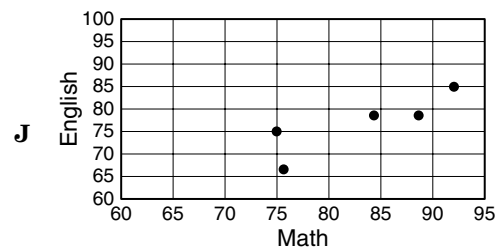
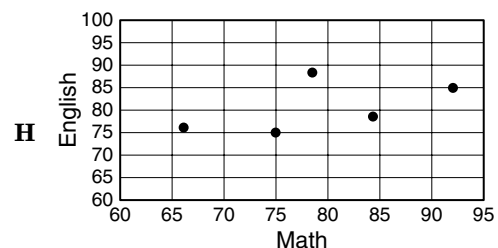
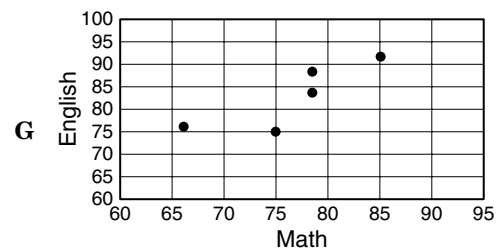
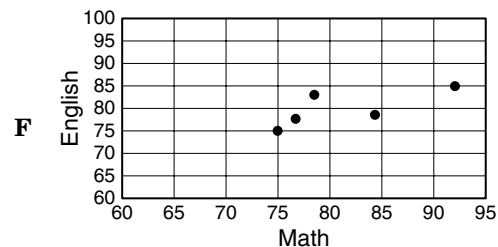

33 Maria's test scores for the grading period are 78, 50, 80, 83, 81, and 50. Which measure would report the highest result?

- A Mean
- B Median
- C Mode
- D Range

34 The graph shows the amount of money earned per week by 5 students in their summer jobs.

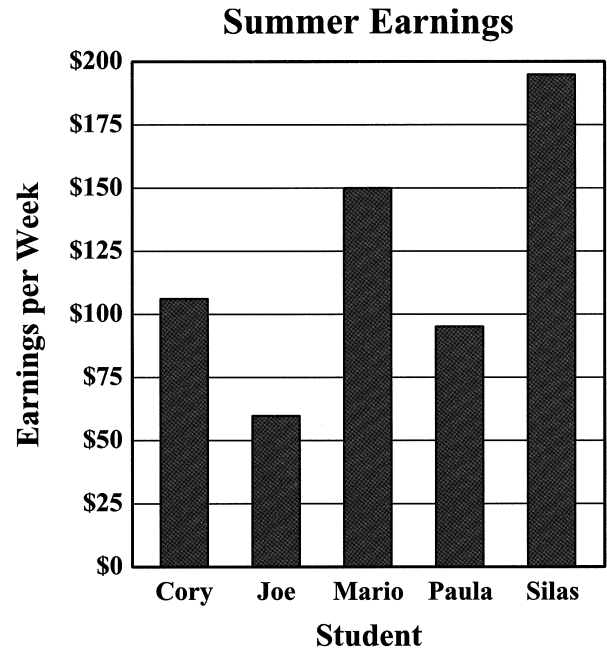

Tynan earned \$80 per week more than Silas. Which could be her weekly salary?

- F \$115
- G \$250
- H \$275
- J \$290

35 The list shows the scores made by each member of Jaime's discussion group on the last test.

69 79 62 93 73 81 73 78

Which box-and-whiskers plot correctly displays the information?

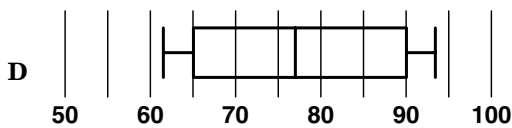
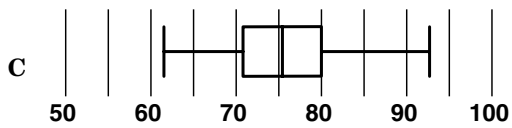
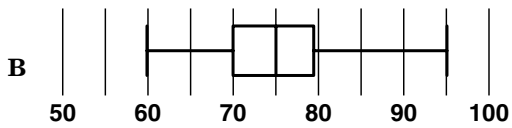
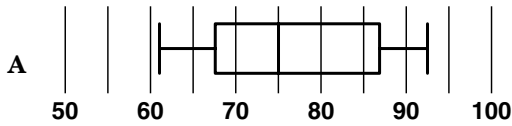

36 This is a list of Beth's English homework scores for the grading period.

93, 83, 64, 84, 76, 83, 78, 76, 60, 81

Which stem-and-leaf plot correctly displays the information?

F

Stem	Leaf
6	
7	
8	
9	

G

Stem	Leaf
6	4
7	6, 8
8	1, 3, 4
9	3

H

Stem	Leaf
6	4
7	6, 6, 8
8	1, 3, 3, 4
9	3

J

Stem	Leaf
6	0, 4
7	6, 6, 8
8	1, 3, 3, 4
9	3

- 37 The graph shows the number of books checked out at the public library each day last week.

**Books Checked Out**

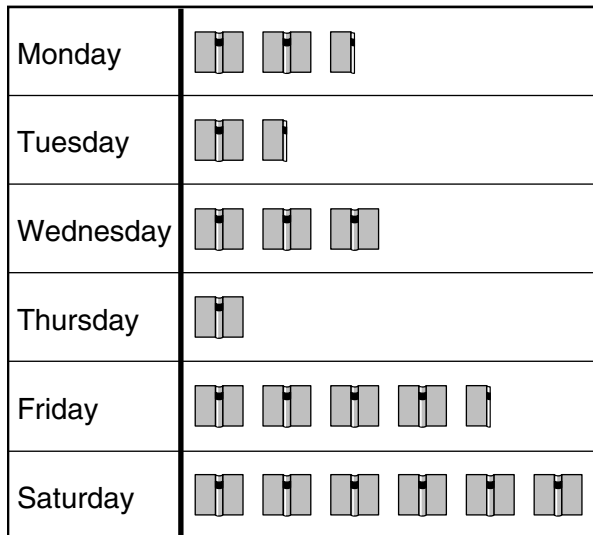

Each represents 10 Books

**On which day were there 3 times as many books checked out as on Tuesday?**

- A Wednesday  
 B Thursday  
 C Friday  
 D Saturday
- 38 Joan and Barry are candidates for class president. Orville, Sally, Consuela, Harry, and Rebecca are candidates for vice president. Sam, William, and Frederica are candidates for secretary. How many different combinations of president, vice president, and secretary are possible?
- F 11  
 G 18  
 H 30  
 J 40

- 39 Dave is a member of a bowling league. The table below shows his record for the last 10 games (100 frames) he bowled.

**Dave's Bowling Results**

Type of Ball	Number of Frames
Strike	12
Spare	26
Gutter ball	3
Other	59

**Based on his previous record, what is the probability that Dave will bowl a strike in the next frame?**

- A  $\frac{3}{100}$   
 B  $\frac{3}{50}$   
 C  $\frac{3}{25}$   
 D  $\frac{6}{25}$

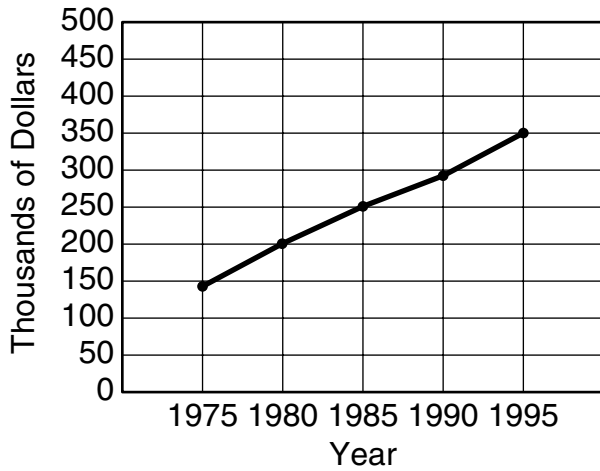
**Gambit Novelty Sales**

The graph shows the annual sales for the Gambit Novelty Company since 1975. Which is the *best* prediction for sales in the year 2005?

- F \$375,000
- G \$400,000
- H \$425,000
- J \$450,000

- 41 Rhea took a survey of the students in her class to find out about their career interests. The results are shown in the graph.

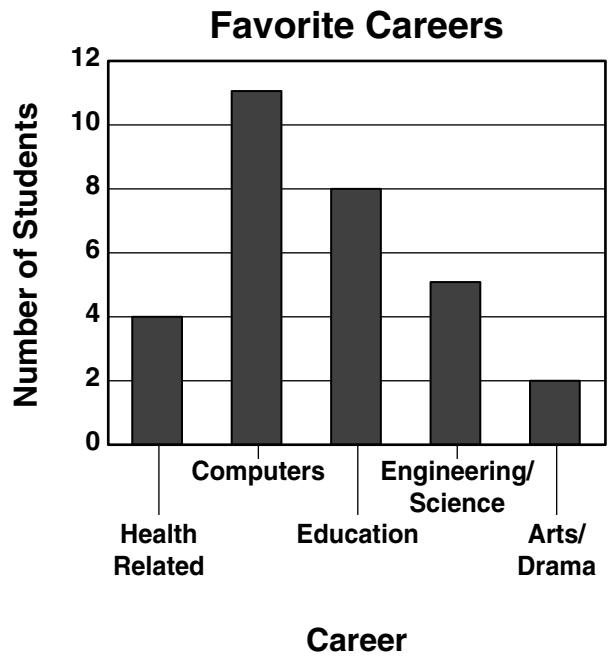

The mode of the data is associated with which career?

- A Health Related
- B Engineering/Science
- C Education
- D Computers

42

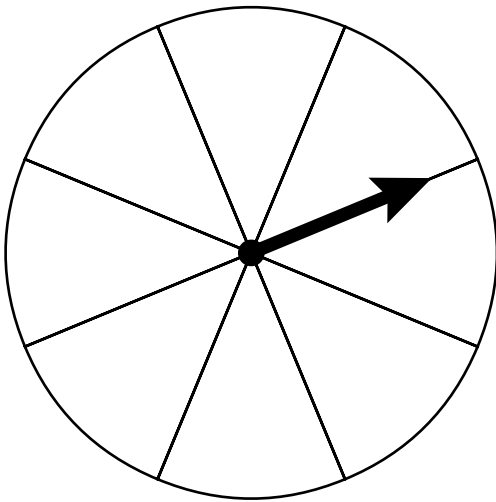

How many of the sections of the spinner shown above should be colored blue in order to make the probability of the arrow landing on blue 0.375 in a single spin?

- F 1
- G 3
- H 5
- J 7

43 Working together, Joy and Steve collected 39 pounds of aluminum cans for recycling. If Joy collected  $j$  pounds, which of the following shows the number of pounds collected by Steve?

- A  $j + 39$
- B  $j - 39$
- C  $39 - j$
- D  $39j$

44

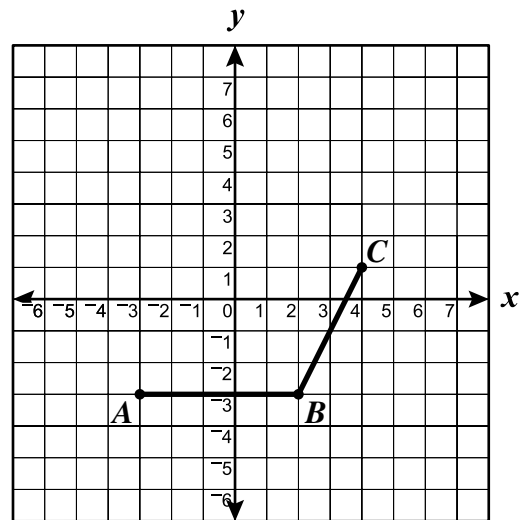

Points  $A$ ,  $B$ , and  $C$  are vertices of a parallelogram. What are the coordinates of the fourth vertex?

- F  $(0, 0)$
- G  $(0, 1)$
- H  $(-1, 1)$
- J  $(-1, -1)$

45 What is the solution to  $5a + 11 + 3a - 7 = -4$ ?

- A  $a = \frac{-11}{4}$
- B  $a = \frac{-7}{4}$
- C  $a = -1$
- D  $a = 0$



- 46 The table shows some elements of a function.

$n$	1	2	3	4
?	$\frac{3}{2}$	$\frac{4}{2}$	$\frac{5}{2}$	$\frac{6}{2}$

What is the missing rule in this table?

- F  $2n$
- G  $\frac{n + 2}{2}$
- H  $\frac{2n + 1}{2}$
- J  $3n$
- 47  $3^4 = 81$
- $3^3 = 27$
- $3^2 = 9$
- $3^1 = 3$
- $3^0 = 1$
- $3^{-1} = \frac{1}{3}$
- $3^{-2} = \frac{1}{9}$
- What is the value of  $3^{-4}$ ?
- A  $\frac{1}{6}$
- B  $\frac{1}{24}$
- C  $\frac{1}{27}$
- D  $\frac{1}{81}$

- 48 If  $\frac{3}{4}(x - 4) = 9$ , what is the value of  $x$ ?

- F 8
- G 12
- H 16
- J  $17\frac{1}{3}$

- 49 A rock that weighed 1.2 pounds on the moon weighed 7.06 pounds on Earth. About how much would an astronaut who weighs 174 pounds on Earth weigh on the moon?

- A 14.5 lbs
- B 24.65 lbs
- C 29.58 lbs
- D 1,023.53 lbs

- 50 Roxanne's car used 4.8 gallons of gasoline to drive 124 miles. If Roxanne has 180 more miles to go, which is *closest* to the additional number of gallons of gasoline the car will use to complete the trip?

- F 2.5
- G 7.0
- H 7.3
- J 14.1

- 51 When any term in this sequence is divided by the previous term, the result is always the same.

3, -6, 12, -24, . . .

What is the 7th term of this sequence?

- A -192
- B -96
- C 96
- D 192

- 52 When 10 is added to the product of 5 and a number, the result is 50. What is the number?

- F 5
- G 8
- H 10
- J 12

- 53 What value of  $x$  satisfies the following?

$$4x + 12 = 100$$

- A 13
- B 22
- C 28
- D 37

- 54 Which of the following is *not* true?

- F  $3x - 8$  is an expression with one variable.
- G  $6x + 2y - 7$  is an expression with 3 terms.
- H In the expression,  $4x + 6y$ , the coefficient of  $x$  is 4.
- J  $5x + 4 = 39$  is an expression.

- 55 What is the solution to  $\frac{1}{2}x + 3 = 7$ ?

- A 2
- B 4
- C 5
- D 8

- 56 What is the solution to  $10x + 13 = 17$ ?

- F  $x = 0.3$
- G  $x = 0.4$
- H  $x = 3.0$
- J  $x = 4.0$

- 57 The table shows some elements of a function.

$n$	?
1	1
2	5
3	9
4	13

What is the missing rule in this table?

- A  $2n - 1$   
 B  $2n + 1$   
 C  $3n$   
 D  $4n - 3$
- 58 Eric is twice as old as his brother Lucas. If 4 is subtracted from Eric's age and 4 is added to Lucas's age, their ages will be equal. What are the boys' ages now?
- F 12 and 6  
 G 14 and 7  
 H 16 and 8  
 J 18 and 9

- 59 Which means "6 less than 5 times a number is 4 more than 3 times that number"?

- A  $5n - 6 = 3n + 4$   
 B  $5(n - 6) = 3(n + 4)$   
 C  $6 - 5n = 4 + 3n$   
 D  $5(3n + 4) = 6$

60

$x$	$y$
2	5
0	1
-2	-3

Which graph shows a line that contains the points in the table of ordered pairs?

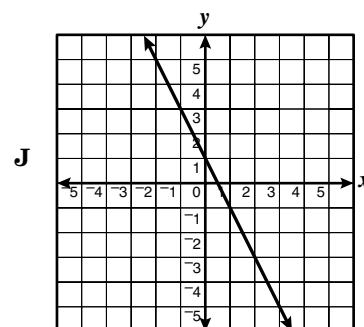
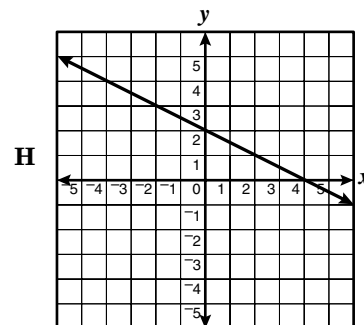
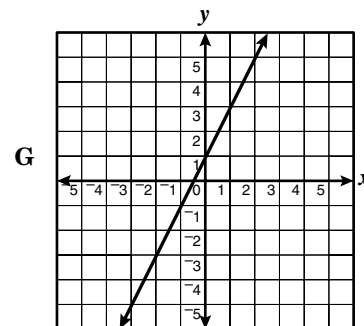
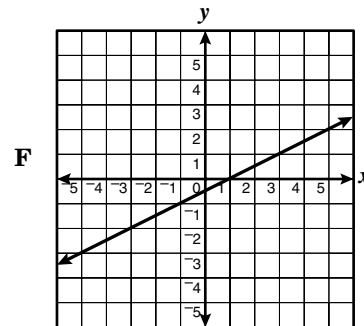

## Answer Key

<b>Test Sequence</b>	<b>Correct Answer</b>	<b>Reporting Category</b>	<b>Reporting Category Description</b>
1	B	005	Number and Number Sense
2	G	005	Number and Number Sense
3	D	005	Number and Number Sense
4	J	005	Number and Number Sense
5	B	005	Number and Number Sense
6	J	005	Number and Number Sense
7	A	005	Number and Number Sense
8	J	005	Number and Number Sense
9	C	006	Computation and Estimation
10	G	006	Computation and Estimation
11	B	006	Computation and Estimation
12	F	006	Computation and Estimation
13	B	006	Computation and Estimation
14	G	006	Computation and Estimation
15	B	006	Computation and Estimation
16	H	007	Measurement and Geometry
17	B	007	Measurement and Geometry
18	G	007	Measurement and Geometry
19	D	007	Measurement and Geometry
20	H	007	Measurement and Geometry
21	C	007	Measurement and Geometry
22	G	007	Measurement and Geometry
23	D	007	Measurement and Geometry
24	H	007	Measurement and Geometry
25	C	007	Measurement and Geometry
26	G	007	Measurement and Geometry
27	C	007	Measurement and Geometry
28	G	007	Measurement and Geometry
29	B	007	Measurement and Geometry
30	G	007	Measurement and Geometry
31	C	008	Probability and Statistics
32	H	008	Probability and Statistics
33	B	008	Probability and Statistics
34	H	008	Probability and Statistics
35	C	008	Probability and Statistics
36	J	008	Probability and Statistics
37	C	008	Probability and Statistics
38	H	008	Probability and Statistics
39	C	008	Probability and Statistics
40	J	008	Probability and Statistics
41	D	008	Probability and Statistics
42	G	008	Probability and Statistics

<b>Test Sequence</b>	<b>Correct Answer</b>	<b>Reporting Category</b>	<b>Reporting Category Description</b>
43	C	009	Patterns, Functions, and Algebra
44	H	009	Patterns, Functions, and Algebra
45	C	009	Patterns, Functions, and Algebra
46	G	009	Patterns, Functions, and Algebra
47	D	009	Patterns, Functions, and Algebra
48	H	009	Patterns, Functions, and Algebra
49	C	009	Patterns, Functions, and Algebra
50	G	009	Patterns, Functions, and Algebra
51	D	009	Patterns, Functions, and Algebra
52	G	009	Patterns, Functions, and Algebra
53	B	009	Patterns, Functions, and Algebra
54	J	009	Patterns, Functions, and Algebra
55	D	009	Patterns, Functions, and Algebra
56	G	009	Patterns, Functions, and Algebra
57	D	009	Patterns, Functions, and Algebra
58	H	009	Patterns, Functions, and Algebra
59	A	009	Patterns, Functions, and Algebra
60	G	009	Patterns, Functions, and Algebra