

**VIRGINIA  
STANDARDS OF LEARNING ASSESSMENTS**

**Spring 2002 Released Test**

---

**END OF COURSE  
GEOMETRY**

# Property of the Virginia Department of Education

© 2002 by the Commonwealth of Virginia Department of Education, James Monroe Building, 101 N. 14th Street, Richmond, Virginia, 23219. All rights reserved. Except as permitted by law, this material may not be reproduced or used in any form or by any means, electronic or mechanical, including photocopying or recording, or by any information storage or retrieval system, without written permission from the copyright owner. Commonwealth of Virginia public school educators may photocopy or print any portion of these Released Tests for educational purposes without requesting permission. All others should direct their requests to the Commonwealth of Virginia Department of Education at (804) 225-2102, Division of Assessment and Reporting.

# Geometry

## DIRECTIONS

Read and solve each question. Then mark the space on the answer sheet for the best answer.

### SAMPLE

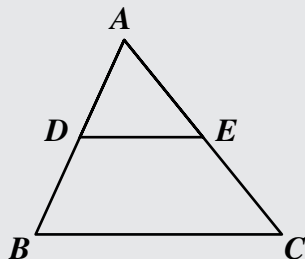

If  $\triangle ABC$  is similar to  $\triangle ADE$ , then  $AB : AD = ? : AE$ . Which replaces the “?” to make the statement true?

- A AC
- B AE
- C DE
- D BC

1

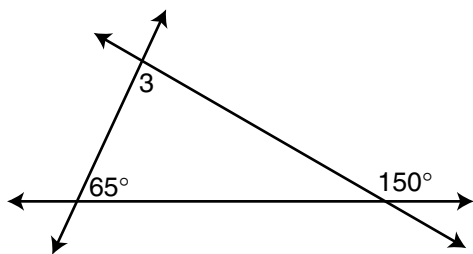

What is  $m\angle 3$ ?

- A  $65^\circ$
- B  $75^\circ$
- C  $85^\circ$
- D  $90^\circ$

2 George used a decorative fencing to enclose his deck.

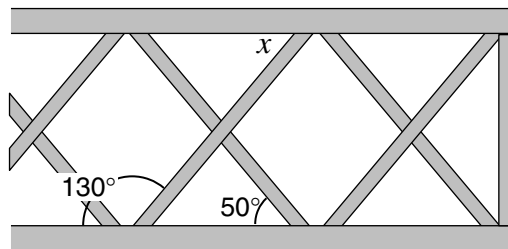

Using the information on the diagram and assuming the top and bottom are parallel, the measure of  $\angle x$  is —

- F  $50^\circ$
- G  $80^\circ$
- H  $100^\circ$
- J  $130^\circ$

3 Angle 1 is a complement of angle 2. If  $m\angle 1 = (14x + 8)$  and  $m\angle 2 = (8x - 6)$ , what is the value of  $x$  and of  $m\angle 1$ ?

- A  $x = 4, m\angle 1 = 26^\circ$
- B  $x = 4, m\angle 1 = 64^\circ$
- C  $x = 113.3, m\angle 1 = 121.3^\circ$
- D  $x = 113.3, m\angle 1 = 58.7^\circ$

- 4 In the figure, lines  $l$  and  $m$  are cut by the transversal  $t$  forming the angles shown.

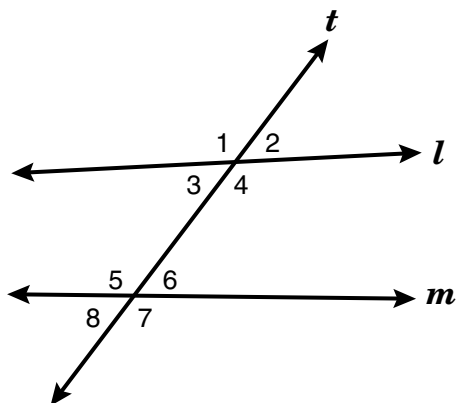

$\angle 3$  and  $\angle 6$  are —

- F Vertical angles
  - G Corresponding angles
  - H Alternate interior angles
  - J Alternate exterior angles
- 5 Use this figure to answer the following.

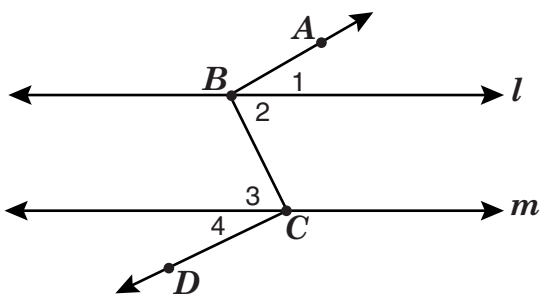

$\overrightarrow{BA}$  is parallel to  $\overrightarrow{CD}$  if —

- A  $m\angle 1 = m\angle 2$
- B  $m\angle 3 = m\angle 4$
- C  $m\angle 1 + m\angle 2 = 90$
- D  $m\angle 1 + m\angle 2 = m\angle 3 + m\angle 4$

6

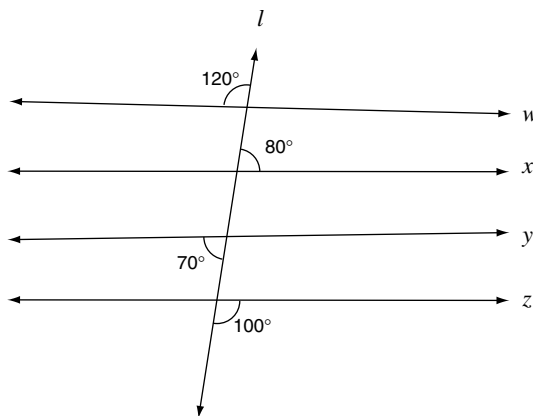

Line  $l$  intersects lines  $w$ ,  $x$ ,  $y$ , and  $z$ . Which two lines are parallel?

- F Line  $w$  and line  $x$
- G Line  $w$  and line  $y$
- H Line  $x$  and line  $z$
- J Line  $y$  and line  $z$

- 7 The measure of  $\angle YZV$  is  $40^\circ$  and the measure of  $\angle XYZ$  is  $65^\circ$ .

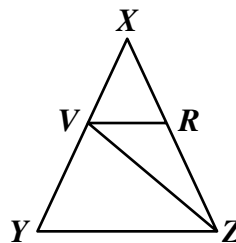

Which of these angles *must* measure  $40^\circ$  in order for  $\overline{VR}$  to be parallel to  $\overline{YZ}$ ?

- A  $\angle YVZ$
- B  $\angle ZVR$
- C  $\angle ZYV$
- D  $\angle VRX$

- 8 Lines  $l$  and  $m$  contain the points shown.

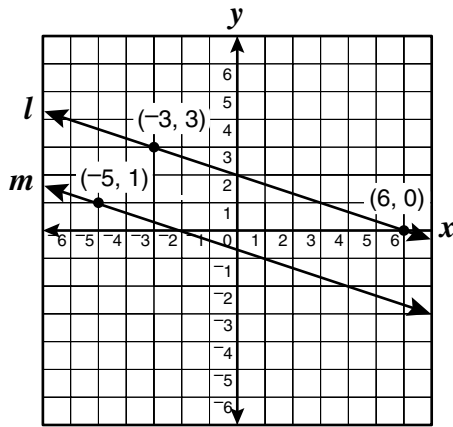

Which of the following points *must* lie on line  $m$  in order for lines  $l$  and  $m$  to be parallel?

- F (0, -2)
- G (0, -1)
- H (1, -1)
- J (4, -1)

- 9 Use a compass, a straightedge, and the drawing below to answer the question.

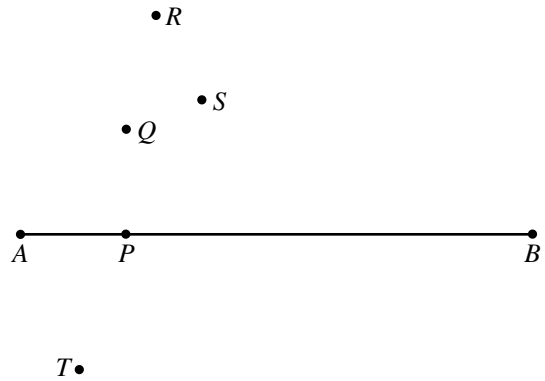

Which point lies on the line through  $P$  perpendicular to  $\overline{AB}$ ?

- A Q
- B R
- C S
- D T

- 10

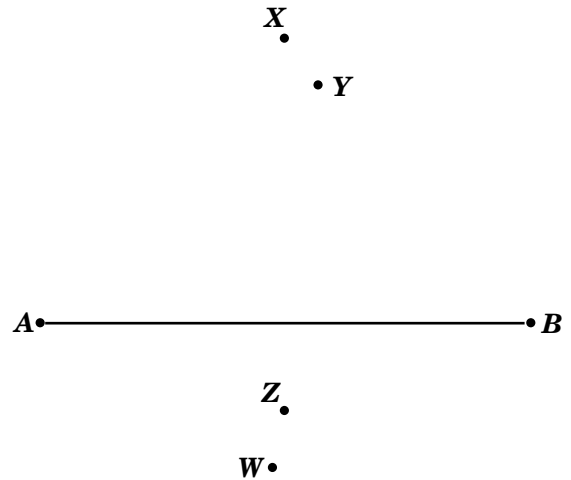

Which pair of points determines the perpendicular bisector of line segment  $\overline{AB}$ ?

- F X,W
- G X,Z
- H Y,W
- J Y,Z

- 11 Use your compass and straightedge to construct the bisector of this angle.

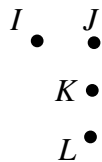
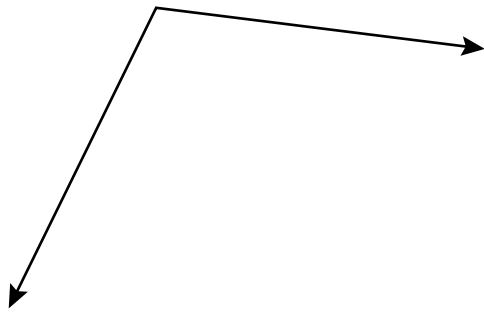

Which point lies on the bisector?

- A *I*
- B *J*
- C *K*
- D *L*

- 12 Which of the following groups of statements represents a valid argument?

- F Given:  $\begin{cases} \text{All quadrilaterals have four sides.} \\ \text{All squares have four sides.} \end{cases}$   
Conclusion: All quadrilaterals are squares.
- G Given:  $\begin{cases} \text{All squares have congruent sides.} \\ \text{All rhombuses have congruent sides.} \end{cases}$   
Conclusion: All rhombuses are squares.
- H Given:  $\begin{cases} \text{All four sided figures are quadrilaterals.} \\ \text{All parallelograms have four sides.} \end{cases}$   
Conclusion: All parallelograms are quadrilaterals.
- J Given:  $\begin{cases} \text{All rectangles have angles.} \\ \text{All squares have angles.} \end{cases}$   
Conclusion: All rectangles are squares.

- 13 Which is the *contrapositive* of the statement, “If I am in Richmond, then I am in Virginia”?

- A If I am in Virginia, then I am in Richmond.
- B If I am not in Richmond, then I am not in Virginia.
- C If I am not in Virginia, then I am not in Richmond.
- D If I am not in Virginia, then I am in Richmond.

14

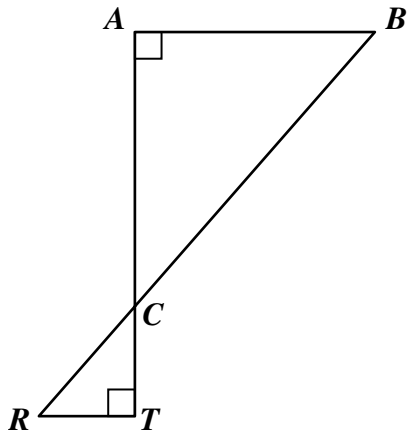

Which of the following correctly describes the relationship between the sides of  $\triangle ABC$  and  $\triangle TRC$ ?

F  $\frac{AB}{TR} = \frac{AC}{RC} = \frac{BC}{TC}$

G  $\frac{AC}{AB} = \frac{BC}{RC} = \frac{TR}{TC}$

H  $\frac{AB}{AC} = \frac{BC}{RC} = \frac{TR}{TC}$

J  $\frac{AB}{TR} = \frac{AC}{TC} = \frac{BC}{RC}$

15 Given:  $\overline{AE}$  and  $\overline{BD}$  bisect each other at  $C$ .

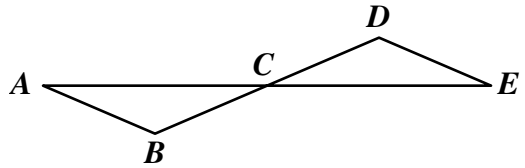

Which could be used to prove  $\triangle ABC \cong \triangle EDC$ ?

- A (SSS) If 3 sides of one triangle are congruent to 3 sides of another triangle, then the triangles are congruent.
- B (SAS) If 2 sides and the angle between them in one triangle are congruent to 2 sides and the angle between them in another triangle, then the triangles are congruent.
- C (ASA) If 2 angles and the side between them of one triangle are congruent to 2 angles and the side between them of another triangle, then the triangles are congruent.
- D (AAS) If 2 angles and a side not between them are congruent to 2 angles and a side not between them of another triangle, then the triangles are congruent.

- 16 A surveyor made this sketch from measurements he made along a river.

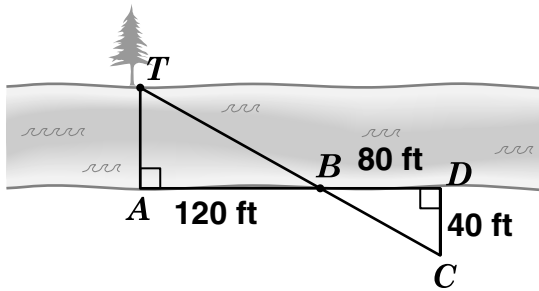

What is the distance across the river from point A to point T?

- F 60 ft
- G 69.3 ft
- H 84.9 ft
- J 120 ft

17

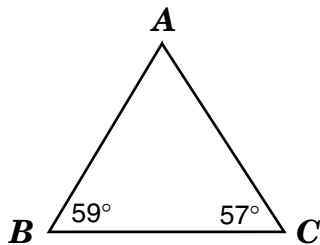

From shortest to longest, the sides of  $\triangle ABC$  are —

- A  $\overline{AC}$ ,  $\overline{BC}$ ,  $\overline{AB}$
- B  $\overline{AB}$ ,  $\overline{BC}$ ,  $\overline{AC}$
- C  $\overline{BC}$ ,  $\overline{AC}$ ,  $\overline{AB}$
- D  $\overline{AB}$ ,  $\overline{AC}$ ,  $\overline{BC}$

- 18 In the drawing, the measure of  $\angle C = 125^\circ$  and the measure of  $\angle B = 35^\circ$ .

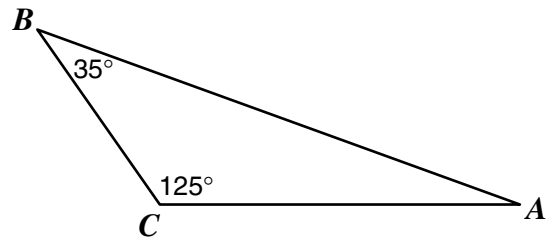

Which is the shortest side of the triangle?

- F  $\overline{AC}$
- G  $\overline{AB}$
- H  $\overline{EB}$
- J  $\overline{BC}$

- 19 On a map, Tannersville, Chadwick, and Barkersville form a triangle. Chadwick is 70 miles from Tannersville and Barkersville is 90 miles from Tannersville. Which is a possible distance between Chadwick and Barkersville?

- A 5 miles
- B 10 miles
- C 150 miles
- D 200 miles



20

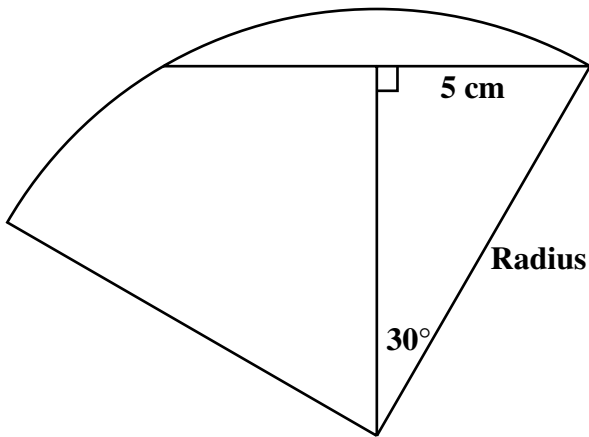

The drawing shows the measurements in a section of a circular design. How long is the radius of the circle?

- F 10 cm
- G 8.7 cm
- H 7 cm
- J 4.3 cm

21 A carpenter is building a flight of stairs as pictured in the drawing.

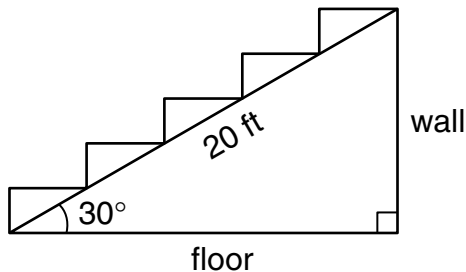

What is the horizontal distance from the foot of the stairs to the wall?

- A 14.1 ft
- B 17.3 ft
- C 20.0 ft
- D 28.3 ft

22 The lengths of 2 consecutive sides of the parallelogram shown are 10 inches and 15 inches. The 2 sides include an angle of  $60^\circ$ .

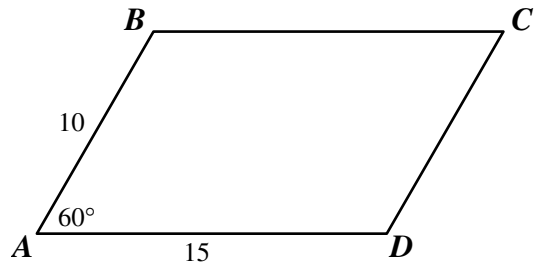

To the nearest tenth of a square inch, what is the area of the parallelogram?

- F 21.6 sq in.
- G 129.9 sq in.
- H 139.4 sq in.
- J 140.5 sq in.

23

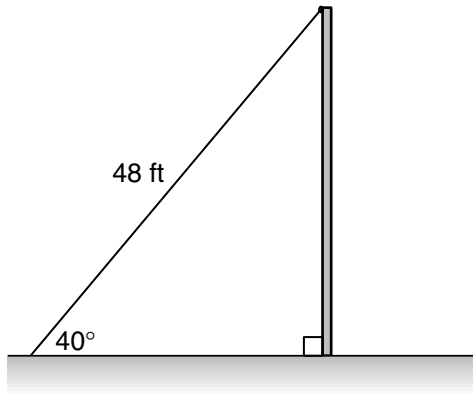

A cable 48 feet long stretches from the top of a pole to the ground. If the cable forms a  $40^\circ$  angle with the ground, which is closest to the height of the pole?

$$\sin 40^\circ \approx 0.642$$

$$\cos 40^\circ \approx 0.766$$

$$\tan 40^\circ \approx 0.839$$

- A 26.4 ft
- B 30.9 ft
- C 36.8 ft
- D 40.3 ft

24

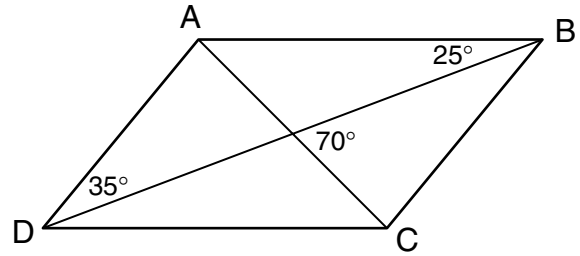

In parallelogram  $ABCD$ , what is  $m\angle BDC$ ?

- F  $70^\circ$
- G  $45^\circ$
- H  $35^\circ$
- J  $25^\circ$

25

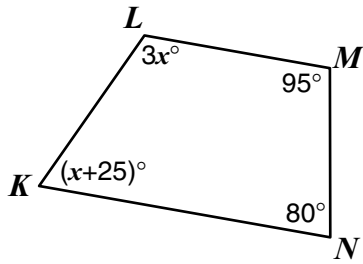

Given quadrilateral  $KLMN$ , what is the value of  $x$ ?

- A 35
- B 40
- C 45
- D 50

26 Three vertices of a parallelogram have coordinates  $(0, 1)$ ,  $(3, 7)$ , and  $(4, 4)$ . You may want to plot the points on this grid.

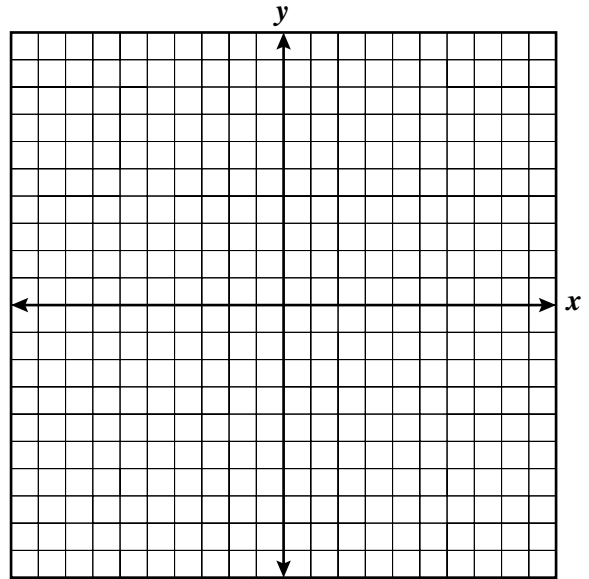

What are the coordinates of the fourth-vertex?

- F  $(-2, 1)$
- G  $(1, -2)$
- H  $(2, -1)$
- J  $(3, 3)$

27

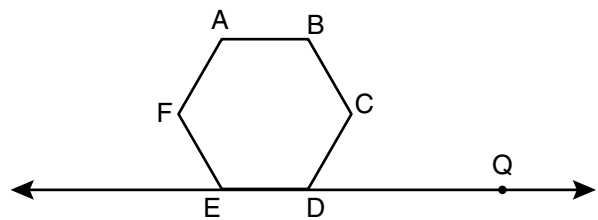
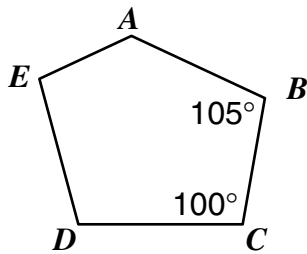

Figure  $ABCDEF$  is a regular hexagon. What is the measure of  $\angle CDQ$ ?

- A  $45^\circ$
- B  $60^\circ$
- C  $90^\circ$
- D  $120^\circ$

- 28 In pentagon  $ABCDE$ ,  $m\angle E = m\angle C$  and  $m\angle D = m\angle B$ .



What is the measure of  $\angle A$ ?

- F  $410^\circ$
  - G  $335^\circ$
  - H  $155^\circ$
  - J  $130^\circ$
- 29 The figure has angle measures as shown.

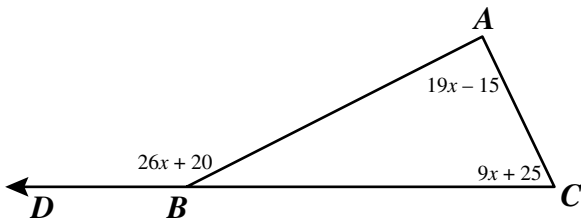

What is the measure of  $\angle ABD$ ?

- A  $150^\circ$
- B  $80^\circ$
- C  $70^\circ$
- D  $30^\circ$

- 30 Triangle  $ABC$  is circumscribed about circle  $O$ .  $P$  and  $Q$  are points of tangency such that  $BP = 3$  and  $CQ = 5$ .

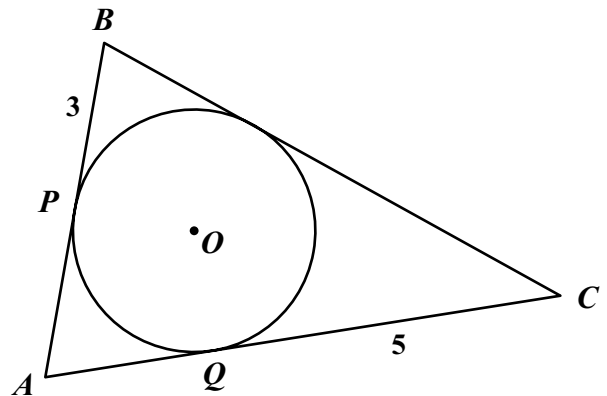

What is the measure of  $\overline{BC}$ ?

- F  $3$
- G  $4$
- H  $5$
- J  $8$

- 31

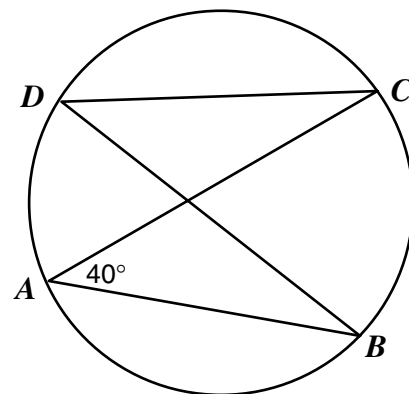

If  $m\angle CAB = 40^\circ$ , what is  $m\angle CDB$ ?

- A  $20^\circ$
- B  $40^\circ$
- C  $60^\circ$
- D  $80^\circ$

- 32  $\overleftrightarrow{AB}$  is tangent to circle  $C$  at  $B$ ,  $AB = 15$  centimeters, and the radius of the circle is 8 centimeters.

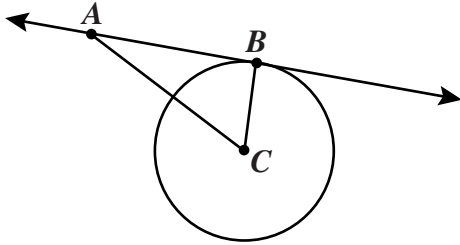

To the nearest tenth of a centimeter, what is the length of  $\overline{AC}$ ?

- F 7.0 cm
  - G 12.7 cm
  - H 17.0 cm
  - J 23.0 cm
- 33 This is a sketch of a stained-glass window in the shape of a semicircle.

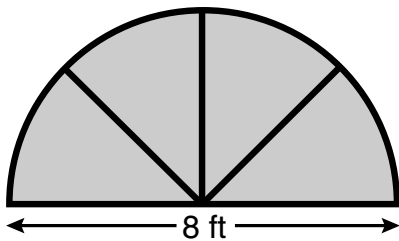

Ignoring the seams, how much glass is needed for the window?

- A  $4\pi$  sq ft
- B  $8\pi$  sq ft
- C  $12\pi$  sq ft
- D  $16\pi$  sq ft

34

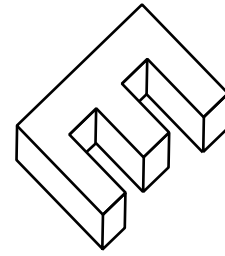

Which are the top, side, and front views of the object shown above?

- F
- G
- H
- J

35

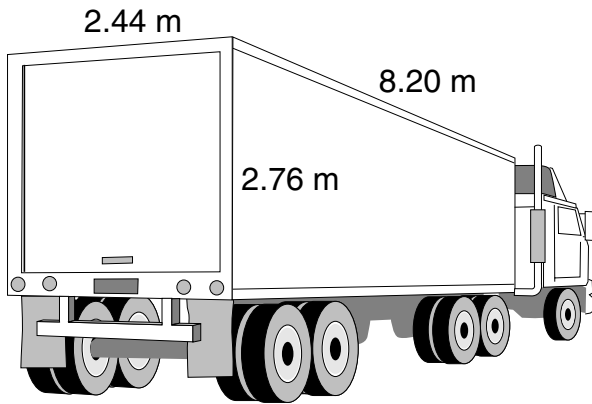

The cargo space of the truck is 2.44 meters wide, 2.76 meters high, and 8.20 meters long. How many cubic meters of cargo space does the truck have?

- A 26.80
- B 55.22
- C 98.75
- D 110.44

36 What is the approximate volume of a can that is 5 inches tall and has a 2.5 inch diameter?

- F 19.6 cu in.
- G 24.5 cu in.
- H 39.3 cu in.
- J 98.1 cu in.

37

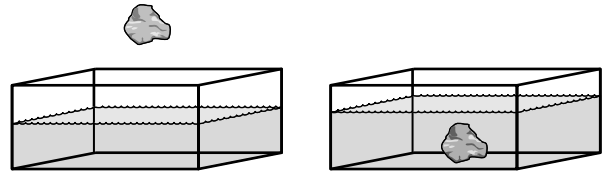

The water level in a rectangular prism tank 40 centimeters by 20 centimeters is 12 centimeters high. A rock submerged in the tank raises the water level 0.4 centimeters. What is the volume of the rock?

- A  $320 \text{ cm}^3$
- B  $960 \text{ cm}^3$
- C  $2,000 \text{ cm}^3$
- D  $9,920 \text{ cm}^3$

38 The ratio between the volumes of two spheres is 27 to 8. What is the ratio between their respective radii?

- F 81:64
- G 27:16
- H 9:8
- J 3:2

39

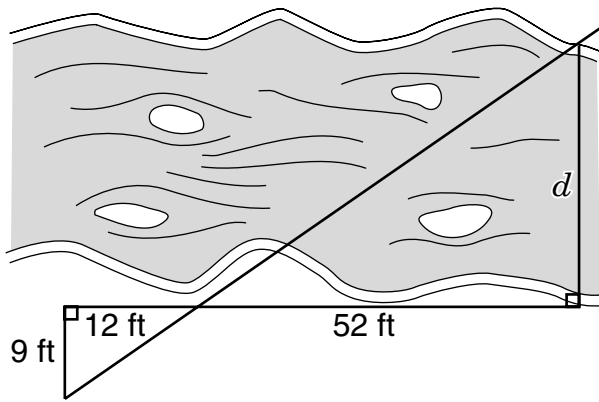

The distance across a river was estimated by making the measurements shown. Which is a good estimate of the distance  $d$ ?

- A 20 ft
- B 30 ft
- C 40 ft
- D 50 ft

40 All the vertices of the hexagon have integral coordinates.

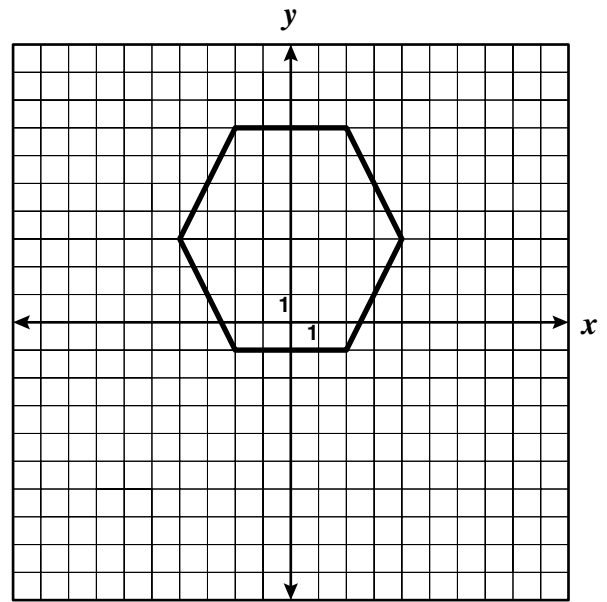

One of the lines of symmetry for the hexagon goes through —

- F  $(-4, 3)$  and  $(4, 3)$
- G  $(-2, -2)$  and  $(2, 7)$
- H  $(-2, 7)$  and  $(2, -2)$
- J  $(2, -2)$  and  $(-2, -7)$

41

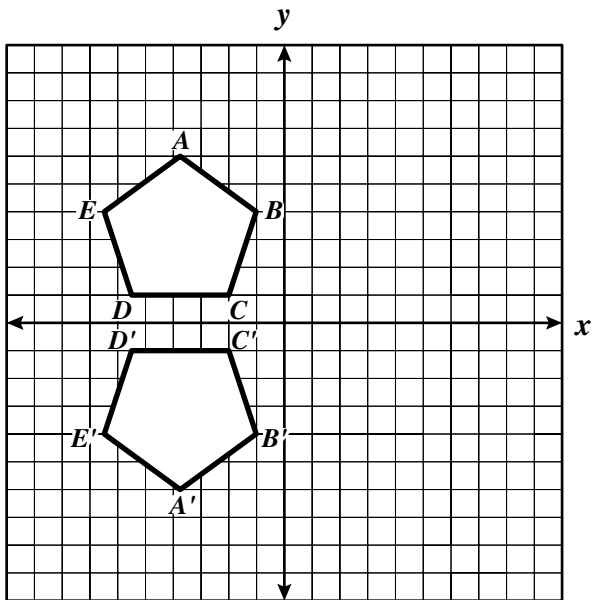

The polygon  $A'B'C'D'E'$  is —

- A a translation of  $ABCDE$  across the  $x$ -axis
- B a  $180^\circ$  clockwise rotation of  $ABCDE$  about the origin
- C a reflection of  $ABCDE$  across the  $y$ -axis
- D a reflection of  $ABCDE$  across the  $x$ -axis

42 If  $\overrightarrow{CD} = (5, 3)$  and  $\overrightarrow{EF} = (7, -4)$ , which column matrix shows the resultant  $\overrightarrow{CD} + \overrightarrow{EF}$ ?

F  $\begin{bmatrix} 12 \\ -7 \end{bmatrix}$

G  $\begin{bmatrix} -7 \\ 12 \end{bmatrix}$

H  $\begin{bmatrix} 12 \\ -1 \end{bmatrix}$

J  $\begin{bmatrix} -1 \\ 12 \end{bmatrix}$

43 The coordinates of the midpoint of  $\overline{AB}$  are  $(-2, 1)$ , and the coordinates of  $A$  are  $(2, 3)$ . What are the coordinates of  $B$ ?

- A  $(0, 2)$
- B  $(-1, 2)$
- C  $(-3, 4)$
- D  $(-6, -1)$



- 44 If  $\overrightarrow{PQ} = (2, 2)$  and  $\overrightarrow{CD} = (3, -2)$ , which is a graph of  $\overrightarrow{PQ} + \overrightarrow{CD}$ ?

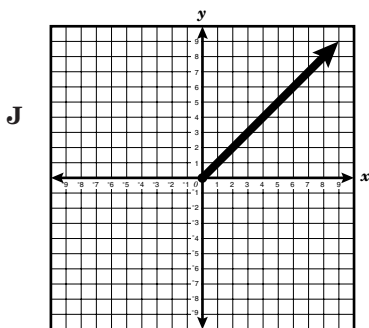
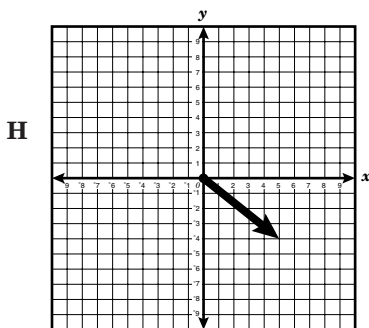
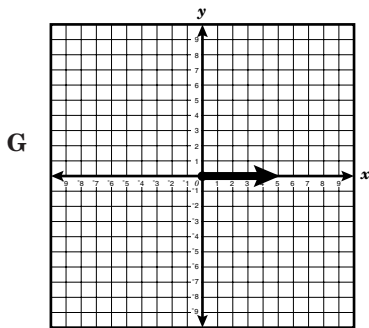
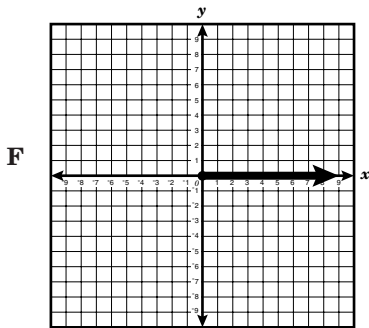

- 45 An airplane is headed due north at 300 nautical miles per hour (knots) as shown in the drawing. The wind is directly from the east at 50 knots.

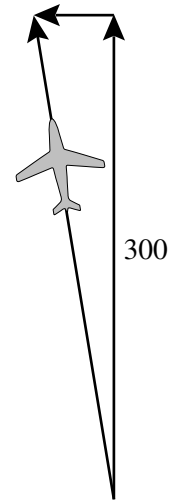

Which is closest to the resultant speed of the airplane?

- A 314 knots
- B 304 knots
- C 296 knots
- D 286 knots

## Answer Key

Test Sequence	Correct Answer	Reporting Category	Reporting Category Description
1	C	001	Lines and Angles
2	F	001	Lines and Angles
3	B	001	Lines and Angles
4	H	001	Lines and Angles
5	D	001	Lines and Angles
6	H	001	Lines and Angles
7	B	001	Lines and Angles
8	H	001	Lines and Angles
9	A	001	Lines and Angles
10	G	001	Lines and Angles
11	C	001	Lines and Angles
12	H	002	Triangles and Logic
13	C	002	Triangles and Logic
14	J	002	Triangles and Logic
15	B	002	Triangles and Logic
16	F	002	Triangles and Logic
17	D	002	Triangles and Logic
18	J	002	Triangles and Logic
19	C	002	Triangles and Logic
20	F	002	Triangles and Logic
21	B	002	Triangles and Logic
22	G	002	Triangles and Logic
23	B	002	Triangles and Logic
24	J	003	Polygons and Circles
25	B	003	Polygons and Circles
26	G	003	Polygons and Circles
27	B	003	Polygons and Circles
28	J	003	Polygons and Circles
29	A	003	Polygons and Circles
30	J	003	Polygons and Circles
31	B	003	Polygons and Circles
32	H	003	Polygons and Circles
33	B	003	Polygons and Circles
34	J	004	Three-Dimensional Figures
35	B	004	Three-Dimensional Figures
36	G	004	Three-Dimensional Figures
37	A	004	Three-Dimensional Figures
38	J	004	Three-Dimensional Figures
39	C	004	Three-Dimensional Figures
40	F	005	Coordinate Relations, Transformations, and Vectors
41	D	005	Coordinate Relations, Transformations, and Vectors
42	H	005	Coordinate Relations, Transformations, and Vectors
43	D	005	Coordinate Relations, Transformations, and Vectors
44	G	005	Coordinate Relations, Transformations, and Vectors
45	B	005	Coordinate Relations, Transformations, and Vectors