

VIRGINIA STANDARDS OF LEARNING

Spring 2008 Released Test

GRADE 7 MATHEMATICS

Form M0118, CORE 1

Property of the Virginia Department of Education

©2008 by the Commonwealth of Virginia, Department of Education, P.O. Box 2120, Richmond, Virginia 23218-2120. All rights reserved. Except as permitted by law, this material may not be reproduced or used in any form or by any means, electronic or mechanical, including photocopying or recording, or by any information storage or retrieval system, without written permission from the copyright owner. Commonwealth of Virginia public school educators may reproduce any portion of these released tests for non-commercial educational purposes without requesting permission. All others should direct their written requests to the Virginia Department of Education, Division of Student Assessment and School Improvement, at the above address or by e-mail to Student_Assessment@doe.virginia.gov.

Grade 7 Mathematics Formula Sheet

Geometric Formulas

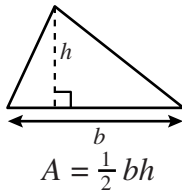

$$A = \frac{1}{2}bh$$

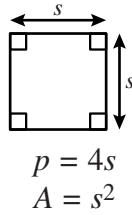

$$p = 4s$$

$$A = s^2$$

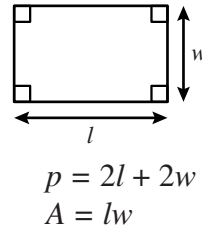

$$p = 2l + 2w$$

$$A = lw$$

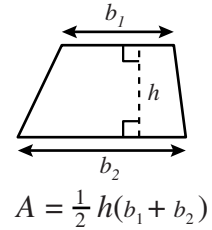

$$A = \frac{1}{2}h(b_1 + b_2)$$

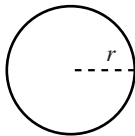

$$C = 2\pi r$$

$$A = \pi r^2$$

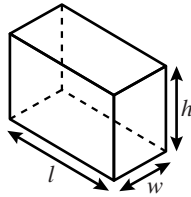

$$V = lwh$$

$$S.A. = 2lw + 2lh + 2wh$$

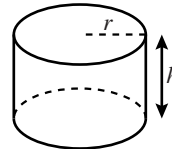

$$V = \pi r^2 h$$

$$S.A. = 2\pi rh + 2\pi r^2$$

Abbreviations

milligram	mg
gram	g
kilogram	kg
milliliter	mL
liter	L
kiloliter	kL
millimeter	mm
centimeter	cm
meter	m
kilometer	km
square centimeter	cm ²
cubic centimeter	cm ³

ounce	oz
pound	lb
quart	qt
gallon	gal.
inch	in.
foot	ft
yard	yd
mile	mi.
square inch	sq in.
square foot	sq ft
cubic inch	cu in.
cubic foot	cu ft

area	A
perimeter	p
circumference	C
volume	V
total surface area	$S.A.$

year	yr
month	mon
hour	hr
minute	min
second	sec

Pi

$$\pi \approx 3.14$$

$$\pi \approx \frac{22}{7}$$

Directions

Read each question and choose the best answer. Then fill in the circle on your answer document for the answer you have chosen.

SAMPLE

One hundred students were asked to name one favorite color. The chart shows the results.

Favorite Colors

Color	Number of Students
Blue	28
Red	21
Purple	11
Green	11
Black	29

What percent of the students named blue?

- A** 28%
- B** 29%
- C** 50%
- D** 57%

1 Ralph’s map of Virginia Beach uses a scale of 1 inch for every 7 miles. Ralph runs a distance of 13.2 miles from his house in Virginia Beach every weekend. Which is closest to the number of inches needed to represent this distance on Ralph’s map?

- A** 7.2 inches
- B** 7.0 inches
- C** 6.2 inches
- D** 1.9 inches

2 Max surveyed students on his website and asked each to select 1 favorite after-school activity. The percents of the total number of students who responded for each activity are shown in the table.

Max’s Survey Results

Activity	Percent
Watching movies	18
Roller skating	10
Listening to music	15
Shopping	14
Basketball	9
Reading	6
Playing games	28

If 126 students selected watching movies, how many total students responded to Max’s survey?

- F** 108
- G** 144
- H** 700
- J** 2,268

3 A jug of drinking water contained $1\frac{1}{2}$ gallons. After one day, $\frac{5}{8}$ gallon had been used. How much water was left in the jug?

- A** $\frac{1}{2}$ gallon
- B** $\frac{7}{8}$ gallon
- C** $1\frac{2}{3}$ gallons
- D** $1\frac{1}{8}$ gallons

4 Kevin mixes paint using 8 ounces of yellow paint for every 3 ounces of white paint. At this rate, how many ounces of white paint would be mixed with 24 ounces of yellow paint?

- F** 8
- G** 9
- H** 19
- J** 64

5 Lynne loaned \$480 to a friend. The friend paid back the amount borrowed plus 10% interest. What was the total amount the friend paid to Lynne?

- A** \$480.10
- B** \$484.80
- C** \$490.00
- D** \$528.00

- 6 Eli can type 1 page in 10 minutes. How many total pages can he type in one hour?
- F 1
 - G 6
 - H 10
 - J 60

- 7 The change in the number of students enrolled at a school over six months is shown in the following table.

School Enrollment

Month	Change
October	-15
November	8
December	3
January	-12
February	3
March	11

The number of students enrolled at the end of September was 4,327. What was the number of students enrolled in the school at the end of March?

- A 4,275
- B 4,300
- C 4,325
- D 4,352

**Do not turn
the page until
you are told.**



8 Which set is ordered *greatest to least*?

F $\left\{ 16\%, \frac{1}{6}, 1.6 \times 10^6, 0.166 \right\}$

G $\left\{ 16\%, 0.166, \frac{1}{6}, 1.6 \times 10^6 \right\}$

H $\left\{ 1.6 \times 10^6, 16\%, \frac{1}{6}, 0.166 \right\}$

J $\left\{ 1.6 \times 10^6, \frac{1}{6}, 0.166, 16\% \right\}$

9 Which property is used in the following number sentence?

$$4(3 + n) = (4 \cdot 3) + (4 \cdot n)$$

- A** Distributive property
- B** Additive inverse property
- C** Associative property of addition
- D** Commutative property of addition

10 Which of the following is another way of expressing 2 out of 8 ?

- F** 2.5%
- G** 25%
- H** 2.5
- J** 25

11 Which list is in order from *least to greatest*?

- A** 0.17, 40%, $\frac{2}{3}$, $\frac{5}{8}$, 0.78
- B** 0.17, 40%, $\frac{5}{8}$, $\frac{2}{3}$, 0.78
- C** 0.78, $\frac{5}{8}$, $\frac{2}{3}$, 40%, 0.17
- D** 0.78, $\frac{2}{3}$, $\frac{5}{8}$, 40%, 0.17

12 The fraction $\frac{1}{8}$ is equivalent to —

- F** 0.012%
- G** 0.125%
- H** 12.5%
- J** 125%

13 Which of the following equations illustrates the multiplicative property of zero?

A $10 \cdot 0 = 0$

B $10 + (-10) = 0$

C $10(15 \cdot 0) = 10(0 \cdot 15)$

D $10(8 + 0) = 10 \cdot 8 + 10 \cdot 0$

14 Which is *false*?

F $35 \div (-30 + 37) = (-35 \div -30) + (-35 \div 37)$

G $(-891 + 345) - 78 = -891 + (345 - 78)$

H $-5 \cdot (-35 + 42) = (-5 \cdot -35) + (-5 \cdot 42)$

J $-62 + 123 = 123 + -62$

15 Which ordered pair describes a point with a location in the second quadrant on a coordinate grid?

A $(-6, -5)$

B $(-6, 5)$

C $(6, -5)$

D $(6, 5)$

16 Which pair of triangles is most likely similar?

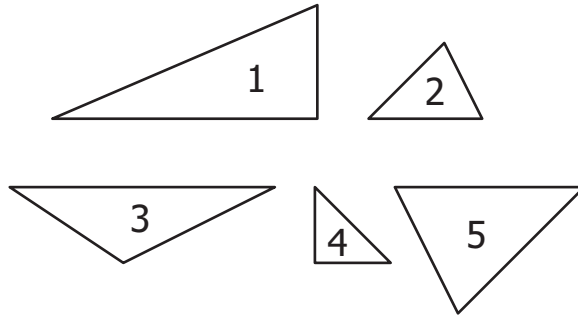

- F 1 and 4
- G 2 and 5
- H 3 and 5
- J 4 and 2

17 Travis is making a wall hanging out of different colors of glass. The shape of the wall hanging is shown on the grid below.

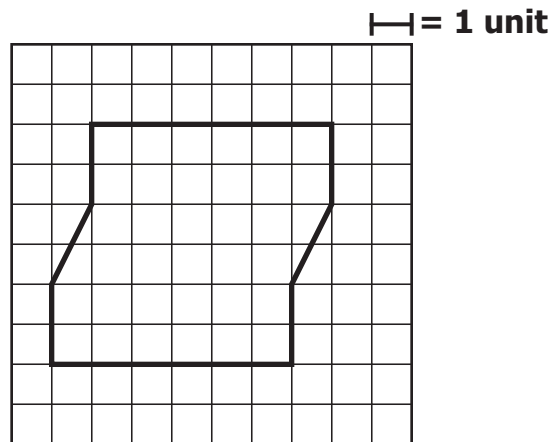

Which is closest to the total amount of glass needed to make the wall hanging?

- A 28 square units
- B 34 square units
- C 36 square units
- D 40 square units

18 Translate the figure vertically 6 positive units.

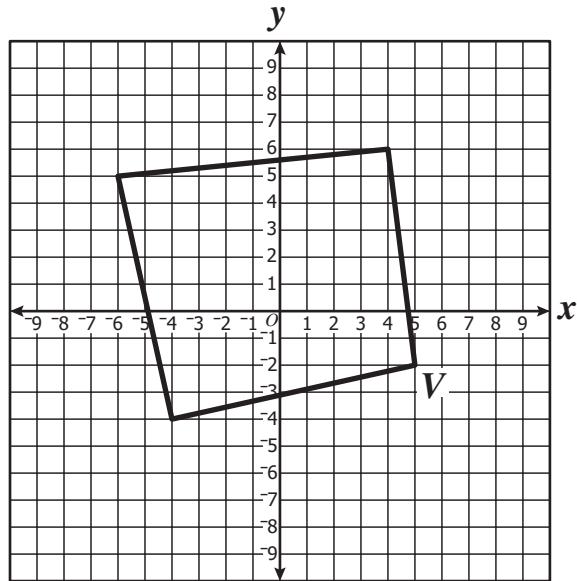

Which best describes the location of the image of vertex V ?

- F (5, -8)
- G (5, 4)
- H (-1, -2)
- J (11, -2)

19 Which of the following is a pentagon?

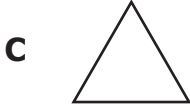
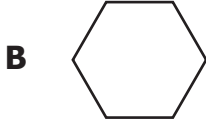

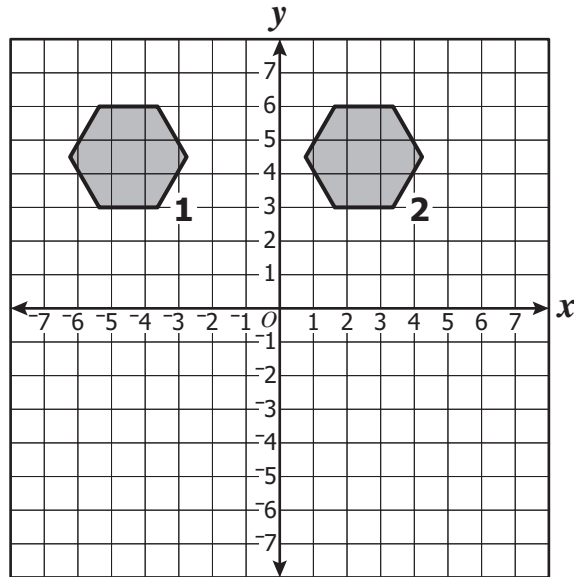

Which is most likely the type of transformation that takes place from Figure 1 to Figure 2 on the coordinate grid above?

- F Rotation about the origin
- G Dilation
- H Translation
- J Reflection across the y -axis

21 The following is true about similar triangles ABC and DEF .

$$\frac{AB}{DE} = \frac{BC}{EF} = \frac{AC}{DF} = \frac{2}{1}$$

Which could be the lengths of \overline{BC} and \overline{EF} ?

- A $BC = 6$ and $EF = 3$
- B $BC = 9$ and $EF = 3$
- C $BC = 3$ and $EF = 6$
- D $BC = 3$ and $EF = 9$

22 Trevor covered a cylindrical can with paper for a project. The can is **18 centimeters tall** and has a **5-centimeter radius**. Which is closest to the minimum amount of paper Trevor needed to cover the entire can?

- F** 283 cm²
- G** 644 cm²
- H** 722 cm²
- J** 1,413 cm²

23 Which of the following quadrilaterals has exactly one pair of parallel sides?

- A** Rhombus
- B** Trapezoid
- C** Rectangle
- D** Parallelogram

24

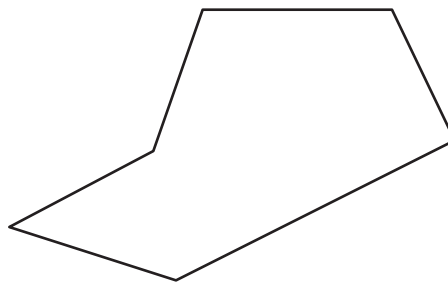

What type of polygon is this?

- F** Pentagon
- G** Heptagon
- H** Hexagon
- J** Decagon

- 25 A powdered drink mix is stored in a cylindrical container that has a radius of 6 centimeters and a height of 14 centimeters. Which is closest to the *maximum* number of cubic centimeters the container will hold?
- A 126 cm^3
 - B 396 cm^3
 - C 504 cm^3
 - D 1,583 cm^3

- 26 Bob wants to paint a rectangular wall that measures 16 feet by 9 feet. The wall contains a window with the dimensions shown.

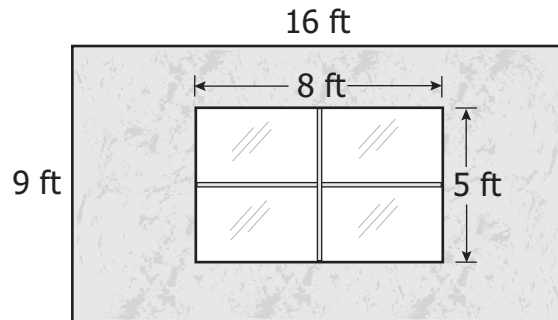

If Bob does not paint the window, what is the total shaded area he will paint?

- F 144 sq ft
- G 104 sq ft
- H 50 sq ft
- J 40 sq ft

- 27 Peter picks one bill at a time from a bag and replaces it. He repeats this process 100 times and records the results in the table.

Peter's Experiment

Value	Frequency
\$1	28
\$5	14
\$10	56
\$20	2

Based on the table, which bill has an experimental probability of $\frac{7}{25}$ for being drawn from the bag next?

- A \$1
- B \$5
- C \$10
- D \$20

- 28 The 9 students in Mr. Smith's P. E. class measured their arm spans and heights. The scatterplot shows the results.

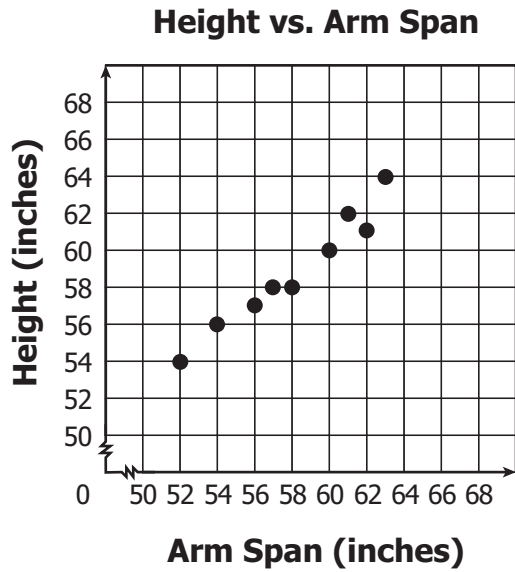

Which data table was *most* likely used to make the scatterplot?

F

Arm Span (inches)	Height (inches)
52	64
54	61
56	62
57	60
58	58
60	58
61	57
62	56
63	54

G

Arm Span (inches)	Height (inches)
54	54
55	56
56	57
57	58
58	58
59	60
60	62
61	61
62	64

H

Arm Span (inches)	Height (inches)
54	52
56	54
57	56
58	57
58	58
60	60
62	61
51	62
64	63

J

Arm Span (inches)	Height (inches)
52	54
54	56
56	57
57	58
58	58
60	60
61	62
62	61
63	64

29 Look at the table.

**Kites Sold for
School Fundraiser**

Year	Number Sold
1	650
2	780
3	540
4	680
5	690

What is the median number of kites sold per year?

- A** 680
- B** 668
- C** 540
- D** 240

30 At Van's Video Store, 30% of the children's movies are animated. If a customer randomly chooses one children's movie, what is the probability that the movie he chooses will be animated?

- F** $\frac{3}{10}$
- G** $\frac{1}{3}$
- H** $\frac{2}{3}$
- J** $\frac{7}{10}$

31 Tim wants his mean (average) quiz score in history class to be 90. His first 3 quiz scores were 86, 92, and 94. What score should he make on the 4th quiz in order to have a mean (average) quiz score of exactly 90 ?

- A** 85
- B** 88
- C** 93
- D** 95

32 Three families are playing a board game and need to form teams of 3 players with 1 player from each family.

Family Members

Guevara Family	Jackson Family	Farris Family
Mariah Stephen Joseph	Sean Zachary Mary	Hannah Erin Edward

How many different teams containing 1 member from each family could be formed?

- F** 3
- G** 9
- H** 18
- J** 27

33 A school club listed the attendance at its weekly meetings as follows.

12, 9, 20, 15, 13, 8, 16, 12, 18, 10, 26, 14, 24, 17, 18

Which statement is *best* supported by the data?

- A** There is no mode.
- B** There is only one mode.
- C** There are only two modes.
- D** There are three modes.

34 What is the lower quartile in the box-and-whisker plot?

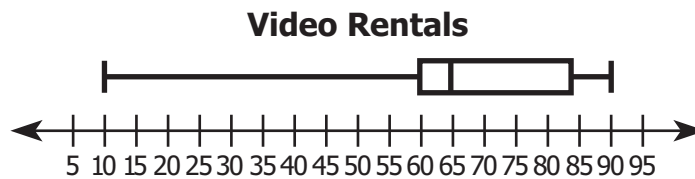

- F** 10
- G** 35
- H** 60
- J** 65

35 The rosebushes in Pattie’s Plant Store have the following colors:

- 20% yellow blooms.
- 50% red blooms.
- 30% pink blooms.

If George selected a rosebush at random today, what is the probability that it will produce yellow blooms?

- A $\frac{1}{5}$
- B $\frac{3}{10}$
- C $\frac{1}{2}$
- D $\frac{4}{5}$

36 The Augusta City Chamber of Commerce computed the average dinner price for two at several area restaurants.

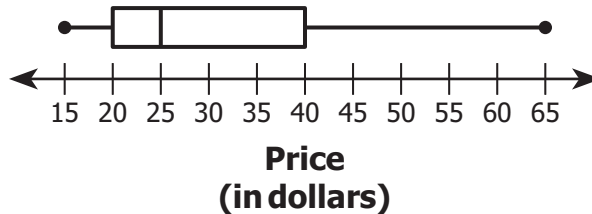

What is the range of the prices displayed in the box-and-whisker plot?

- F 20
- G 25
- H 50
- J 65

37 Which scatterplot *best* shows there is no significant relationship between the heights of a group of people and the total amount of money they spend on food each week?

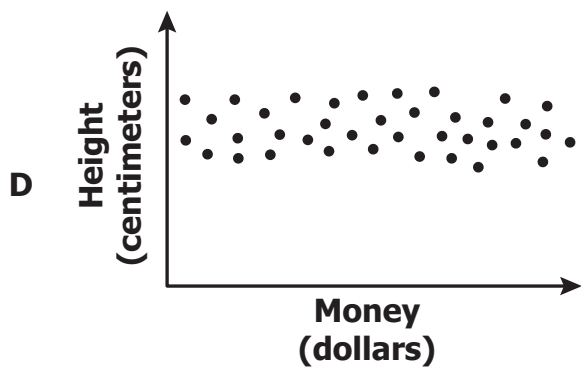
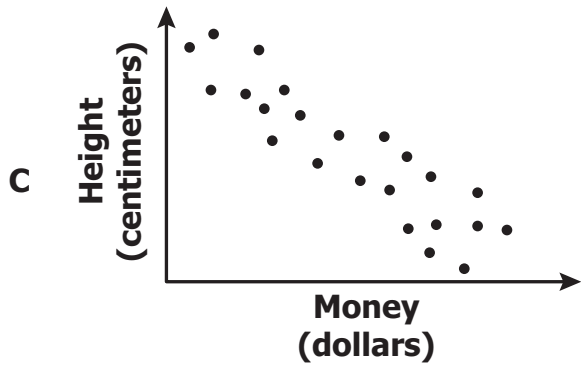
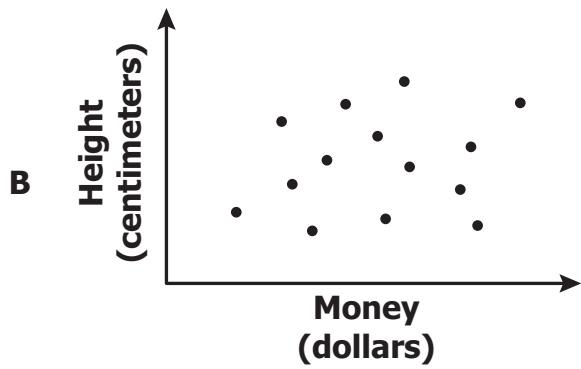
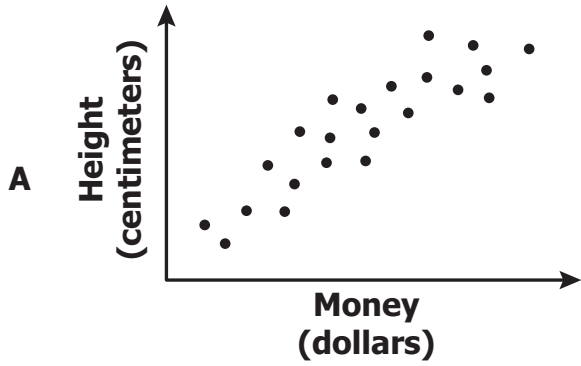

38 Jackie is in a fashion show at school. For her first outfit she may choose from 3 different colored shirts, 2 pairs of pants, and 3 pairs of shoes. From how many different possible outfits of 1 shirt, 1 pair of pants, and 1 pair of shoes can Jackie choose?

- F** 3
- G** 8
- H** 11
- J** 18

39 Kirk wrote the number pattern shown below.

0, 2, 5, 9, 14, 20

He found that the differences between the numbers increased by 1 as shown below.

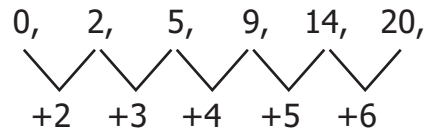

If the differences continue to increase by 1, what will be the 9th number in Kirk's original pattern?

- A** 35
- B** 38
- C** 44
- D** 54

40 Which phrase best represents the following?

$$\frac{n}{5} + 7$$

- F** Seven added to the quotient of a number and five
- G** Seven added to the quotient of five and a number
- H** The sum of seven and five divided by a number
- J** Five divided by a number added to seven

41 Which represents *all* the values for u that make the following true?

$$u + 5 > 7$$

- A** $u > 2$
- B** $u > 12$
- C** $u < 2$
- D** $u < 12$

42 What value of p makes the following true?

$$p - 4.5 = 2.5$$

- F** -7.0
- G** -2.0
- H** 2.0
- J** 7.0

43 What is the solution to the number sentence?

$$\frac{c}{10} = 40$$

- A** $c = 4$
- B** $c = 30$
- C** $c = 50$
- D** $c = 400$

44 Which could be used to find the number n ?

Four less than a number, n , is equal to fifteen.

- F** $n - 4 = 15$
- G** $4 - n = 15$
- H** $n - 15 = 4$
- J** $15 - n = 4$

45 Ginger spent \$24 at the fair, which was three times the amount she spent last year at the fair. How much money did Ginger spend last year at the fair?

- A** \$8
- B** \$21
- C** \$27
- D** \$72

46 $6z > 36$

The above is —

- F an expression
- G an equation
- H an inequality
- J a variable

47 A large box contains 11 smaller boxes of raisins. The price of the large box is \$2.75. Each of the smaller boxes of raisins costs the same amount. Which could be used to find d , the price of a smaller box?

- A $11d = 2.75$
- B $d + 11 = 2.75$
- C $d - 11 = 2.75$
- D $\frac{d}{11} = 2.75$

48 Which table contains *only* values that satisfy the following?

$$y = x + 5$$

F

x	y
-5	0
-1	6
2	7

G

x	y
-5	0
-1	4
5	10

H

x	y
0	-5
4	-1
10	5

J

x	y
0	-5
6	-1
7	2

49 The graph displays the relationship between time and profit.

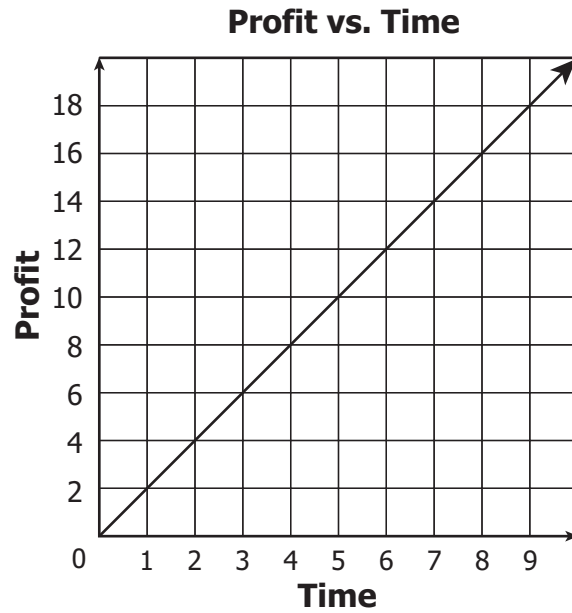

Which equation represents the relationship between time (t) and profit (P) ?

A $P = \frac{1}{2}t$

B $P = t$

C $P = 2t$

D $P = 3t$

50 Which is an expression?

F $5x + 3$

G $5x = 3$

H $5x \geq 3$

J $5x < 3$



Answer Key-7074-M0118

Test Sequence Number	Correct Answer	Reporting Category	Reporting Category Description
1	D	002	Computation and Estimation
2	H	002	Computation and Estimation
3	B	002	Computation and Estimation
4	G	002	Computation and Estimation
5	D	002	Computation and Estimation
6	G	002	Computation and Estimation
7	C	002	Computation and Estimation
8	J	001	Number and Number Sense
9	A	001	Number and Number Sense
10	G	001	Number and Number Sense
11	B	001	Number and Number Sense
12	H	001	Number and Number Sense
13	A	001	Number and Number Sense
14	F	001	Number and Number Sense
15	B	003	Measurement and Geometry
16	G	003	Measurement and Geometry
17	C	003	Measurement and Geometry
18	G	003	Measurement and Geometry
19	D	003	Measurement and Geometry
20	H	003	Measurement and Geometry
21	A	003	Measurement and Geometry
22	H	003	Measurement and Geometry
23	B	003	Measurement and Geometry
24	H	003	Measurement and Geometry
25	D	003	Measurement and Geometry
26	G	003	Measurement and Geometry
27	A	004	Probability and Statistics
28	J	004	Probability and Statistics
29	A	004	Probability and Statistics
30	F	004	Probability and Statistics
31	B	004	Probability and Statistics
32	J	004	Probability and Statistics
33	C	004	Probability and Statistics
34	H	004	Probability and Statistics
35	A	004	Probability and Statistics
36	H	004	Probability and Statistics
37	B	004	Probability and Statistics
38	J	004	Probability and Statistics
39	C	005	Patterns, Functions, and Algebra
40	F	005	Patterns, Functions, and Algebra
41	A	005	Patterns, Functions, and Algebra
42	J	005	Patterns, Functions, and Algebra
43	D	005	Patterns, Functions, and Algebra
44	F	005	Patterns, Functions, and Algebra
45	A	005	Patterns, Functions, and Algebra
46	H	005	Patterns, Functions, and Algebra
47	A	005	Patterns, Functions, and Algebra
48	G	005	Patterns, Functions, and Algebra
49	C	005	Patterns, Functions, and Algebra
50	F	005	Patterns, Functions, and Algebra

Grade 7 Math, Core 1

If you get this many items correct:	Then your converted scale score is:
0	000
1	026
2	083
3	117
4	143
5	163
6	180
7	194
8	208
9	219
10	230
11	241
12	250
13	260
14	268
15	277
16	285
17	293
18	300
19	308
20	315
21	323
22	330
23	337
24	344
25	351
26	358
27	365
28	372
29	380
30	387
31	394
32	402
33	410
34	417
35	426
36	434
37	443
38	452
39	462
40	472
41	483
42	495
43	508
44	523
45	540
46	560
47	585
48	600
49	600
50	600